

BLAZE

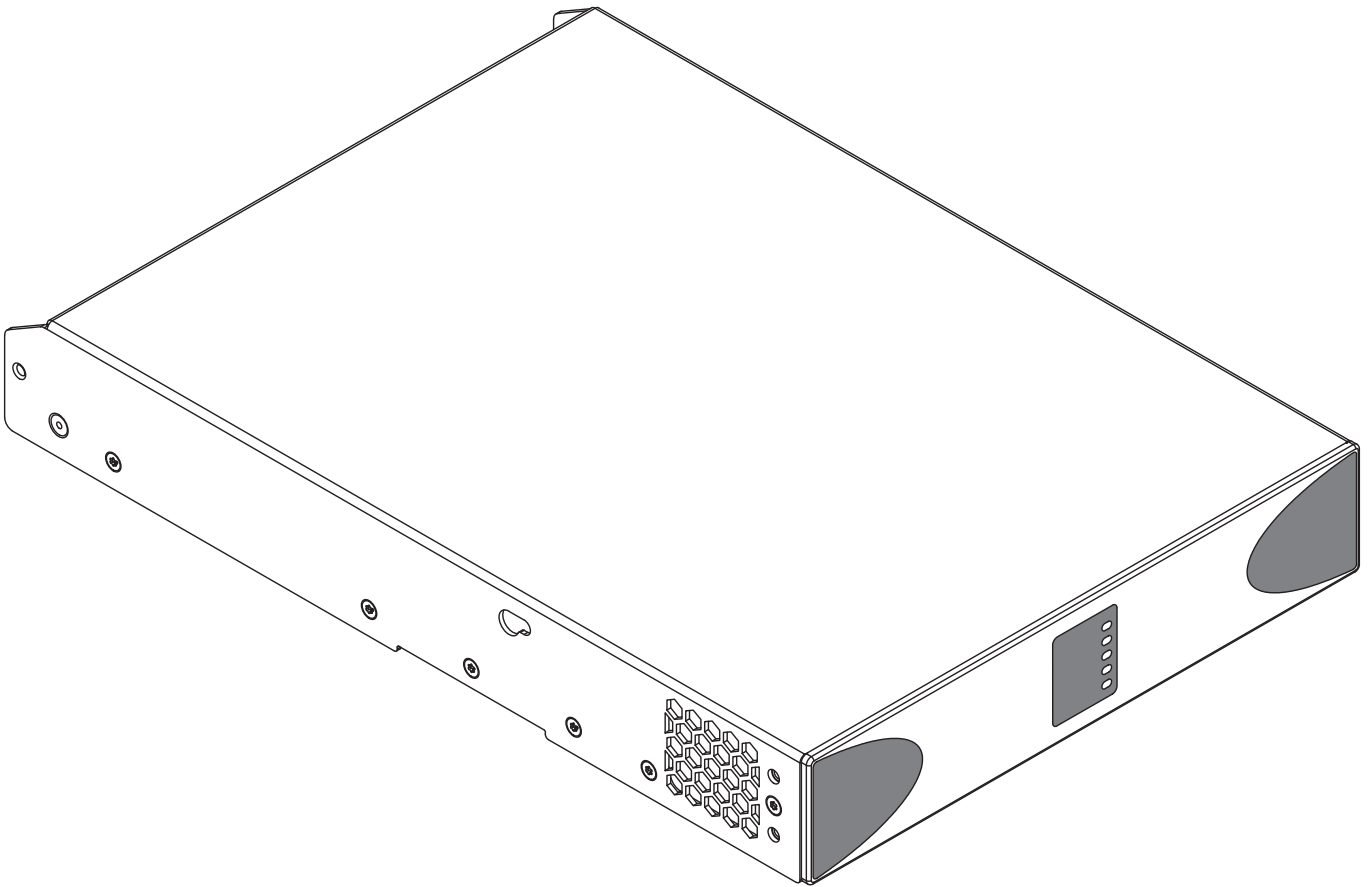

INSTALLATION GUIDE / USER MANUAL

PowerZone Connect 122 • PowerZone Connect 252

PowerZone Connect 254 • PowerZone Connect 504

Technical and Safety Notices

Please read the following important technical, safety and environmental notices before installing and using your amplifier.

Technical Notices

All reasonable design and engineering steps have been taken to ensure that these amplifiers always perform satisfactorily in their intended application and environment and will provide appropriate levels of support to ensure that all reasonable customer needs and expectations are met. Such support however is contingent on the following provisions.

1. These amplifiers are Class-I products and should be installed with a mains cable including the required earth connection to comply with the Safety Class-I.
2. These amplifiers should always be installed by competent and qualified personnel. Amplifier damage or failure caused by installation or operational errors may invalidate support, warranty or guarantees of performance.
3. These amplifiers are not suitable for use in locations where they may be accessible to minors.
4. These amplifiers are intended to be used specifically for the amplification of audio signals and for connection to moving-coil loudspeaker systems. Use of these amplifiers for amplification of signals outside the audio band (20Hz to 20kHz) or to drive transducers other than moving-coil loudspeakers may invalidate support, warranty or guarantees of performance.
5. These amplifiers should only be used within professionally installed and configured audio systems comprising input and output ancillary equipments that is known to be of an appropriate level of performance and in good operating condition. Any damage to, or unsatisfactory performance from, these amplifiers caused by inadequate or failed input or output ancillaries may invalidate support, warranty or guarantees of performance.
6. These amplifiers are intended to be installed and operated indoor in a controlled environment (pollution degree, PD2) within an ambient temperature range of 0°C to 40°C. These amplifiers are not intended for use above 2000 meters above sea level. Amplifiers installation or operated in environments outside these limits may invalidate support, warranty or guarantees of performance.
7. Specific warranty terms are the responsibility of the amplifier re-seller.

Safety and Environmental Notices

Note: The intent of the lightning flash with arrowhead symbol in a triangle is to alert the user to the presence of uninsulated "dangerous" voltage within the product's enclosure that may be of sufficient magnitude to constitute a risk of electric shock to humans.

Note: The intent of the exclamation point within an equilateral triangle is to alert the user to the presence of important safety, and operating and maintenance instructions in this manual.

WARNING! TO PREVENT FIRE OR ELECTRIC SHOCK, DO NOT EXPOSE THIS EQUIPMENT TO RAIN OR MOISTURE.

Ambient Temperature Note: If this equipment is operated in a confined or multiple rack installation, the internal ambient operating temperature may exceed the external ambient temperature.



It is important to ensure in these circumstances that the published maximum operating temperature for the equipment is not exceeded.



Reduced Air Flow: Ensure that rack or other closed installation does not restrict the cooling airflow required for safe and reliable operation of the equipment.

Technical and Safety Notices

Important Safety Instructions

1. Read these instructions.
2. Keep these instructions.
3. Heed all warnings.
4. Follow all instructions.
5. Do not use this apparatus near water.
6. Do not submerge the equipment in water or liquids.
7. Do not use any aerosol spray, cleaner, disinfectant or fumigant on, near or into the equipment.
8. Clean only with a dry cloth.
9. Do not block any ventilation opening. Install in accordance with the manufacturer's instructions.
10. Do not install near any heat sources such as radiators, heat registers, stoves, or other apparatus (including amplifiers) that produce heat.
11. To reduce the risk of electrical shock, the power cord shall be connected to a mains socket outlet with a protective earthing connection.
12. Do not defeat the safety purpose of the polarized or grounding type plug. A polarized plug has two blades with one wider than the other. A grounding type plug has two blades and a third grounding prong. The wide blade or the third prong are provided for your safety. If the provided plug does not fit into your outlet, consult an electrician for replacement of the obsolete outlet.
13. Protect the power cord from being walked on or pinched particularly at plugs, convenience receptacles, and the point where they exit from the apparatus.
14. Do not unplug the unit by pulling on the cord, use the plug.
15. Only use attachments/accessories specified by the manufacturer.
16. Unplug this apparatus during lightning storms or when unused for long periods of time.
17. Refer all servicing to qualified service personnel. Servicing is required when the apparatus has been damaged in any way, such as power supply cord or plug is damaged, liquid has been spilled or objects have fallen into the apparatus, the apparatus has been exposed to rain or moisture, does not operate normally, or has been dropped.
18. The appliance coupler, or the AC Mains plug, is the AC mains disconnect device and shall remain readily accessible after installation.
19. Adhere to all applicable, local codes.
20. Consult a licensed, professional engineer when any doubt or questions arise regarding a physical equipment installation.

Environmental Statement



This product complies with international directives, including but not limited to the Restriction of Hazardous Substances (RoHS) in electrical and electronic equipment, the Registration, Evaluation, Authorization and restriction of Chemicals (REACH) and the disposal of Waste Electrical and Electronic Equipment (WEEE). Consult your local waste disposal authority for guidance on how properly to recycle or dispose of this product.

Introduction and Overview

1. Introduction

Blaze PowerZone Connect DSP power amplifiers have been designed to provide configurable, consistent and reliable high performance audio power amplification for residential, commercial and entertainment applications. Please read this manual fully before installing and using an amplifier. If you have any questions regarding amplifier configuration, installation or operation please contact the appropriate customer support portal.

Following this introduction, the manual is divided into sections covering the following topics:

- Overview
- Carton Contents
- Installation
- Configuration
- Connections
- Operation
- Specifications

2. Amplifier Overview

2.1 Model Range

PowerZone Connect 122

The **PowerZone Connect 122** DSP amplifier is a half rack width, 1U format power amplifier that can drive both conventional low impedance (Lo-Z, 4Ω to 16Ω) loudspeakers and high impedance (Hi-Z, 70V/100V) transformer coupled loudspeakers. The **PowerZone Connect 122** provides four analog inputs, one stereo S/PDIF digital input, and two outputs (Lo-Z mode) or one output (Hi-Z mode). It is capable of a maximum output of 60 Watts per channel into Lo-Z loads or 125 Watts into Hi-Z loads. The **PowerZone Connect 122** also incorporates automatic power sharing technology that enables 125 Watts to be shared proportionately as required between the two outputs in Lo-Z mode.

PowerZone Connect 252

The **PowerZone Connect 252** DSP amplifier is a half rack width, 1U format power amplifier that can drive both conventional low impedance (Lo-Z, 4Ω to 16Ω) loudspeakers and high impedance (Hi-Z, 70V/100V) transformer coupled loudspeakers. The **PowerZone Connect 252** provides four analog inputs, one stereo S/PDIF digital input, and two outputs (Lo-Z mode) or one output (Hi-Z mode). It is capable of a maximum output of 125 Watts per channel into Lo-Z loads or 250 Watts into Hi-Z loads. The **PowerZone Connect 252** also incorporates automatic power sharing technology that enables 250 Watts to be shared proportionately as required across the two outputs in Lo-Z mode.

PowerZone Connect 254

The **PowerZone Connect 254** DSP amplifier is a half rack width, 1U format power amplifier that can drive both conventional low impedance (Lo-Z, 4Ω to 16Ω) loudspeakers and high impedance (Hi-Z, 70V/100V) transformer coupled loudspeakers. The **PowerZone Connect 254** provides four analog inputs, one stereo S/PDIF digital input, and four outputs (Lo-Z mode) or two outputs (Hi-Z mode). It is capable of a maximum output of 60 Watts per channel into Lo-Z loads or 125 Watts into Hi-Z loads. The **PowerZone Connect 254** also incorporates automatic power sharing technology that enables 250 Watts to be shared proportionately as required across the four outputs in Lo-Z mode and the two outputs in Hi-Z mode.

PowerZone Connect 504

The **PowerZone Connect 504** amplifier is a half rack width, 1U format power amplifier that can drive both conventional low impedance (Lo-Z, 4Ω to 16Ω) loudspeakers and high impedance (Hi-Z, 70V/100V) transformer coupled loudspeakers. The **PowerZone Connect 504** provides four analog inputs, one stereo S/PDIF digital input, and four outputs (Lo-Z mode) or two outputs (Hi-Z mode). It is capable of a maximum output of 125 Watts per channel into Lo-Z loads or 250 Watts per channel into Hi-Z loads. The **PowerZone Connect 504** also incorporates automatic power sharing technology that enables 250 Watts to be shared proportionately as required across each output pair in Lo-Z mode and the two outputs in Hi-Z mode.

Introduction and Overview

2.2 Connections

PowerZone Connect signal input and output connections are accomplished via RCA Phono and Euroblock style connectors. A GPIO (General Purpose In/Out) Euroblock connector enables some amplifier functions to be controlled, and wireless or RJ45 socket Ethernet network connection options are also provided.

PowerZone Connect amplifiers have no mains power switch and are operational as soon as mains power is connected via the IEC 60320 mains socket.

2.3 Network Features

PowerZone Connect amplifiers are TCP/IP network connected devices that require a wired or wireless network connection to access their configuration menus. The configuration menus are accessed via a web page interface and cover Input, Zone, Output and General Settings functions. The configuration menus are fully described in **Section 4** of this manual.

2.4 Dimensions

PowerZone Connect amplifier dimensions and features are illustrated in **Diagrams 1a and 1b**. The amplifiers are primarily intended for installation in an equipment rack but can also be under-desk or wall mounted, or used free standing. They are fan-cooled and must be installed such that ventilation apertures are not obstructed.

3. Carton Contents

PowerZone Connect amplifiers are shipped in a cardboard carton containing the amplifier unit, a mains cable appropriate for the sales territory, an accessory pack, and a document pack. The full contents is listed below.

- Amplifier unit
- Mains power cable
- Input connector x 2
- GPIO socket connector
- Output connector x 1 or 2
- Adhesive rubber feet x 4
- Document pack

Overview

Diagram 1a

PowerZone Connect two channel amplifier dimensions.
(Shaded area defines ventilation space.)

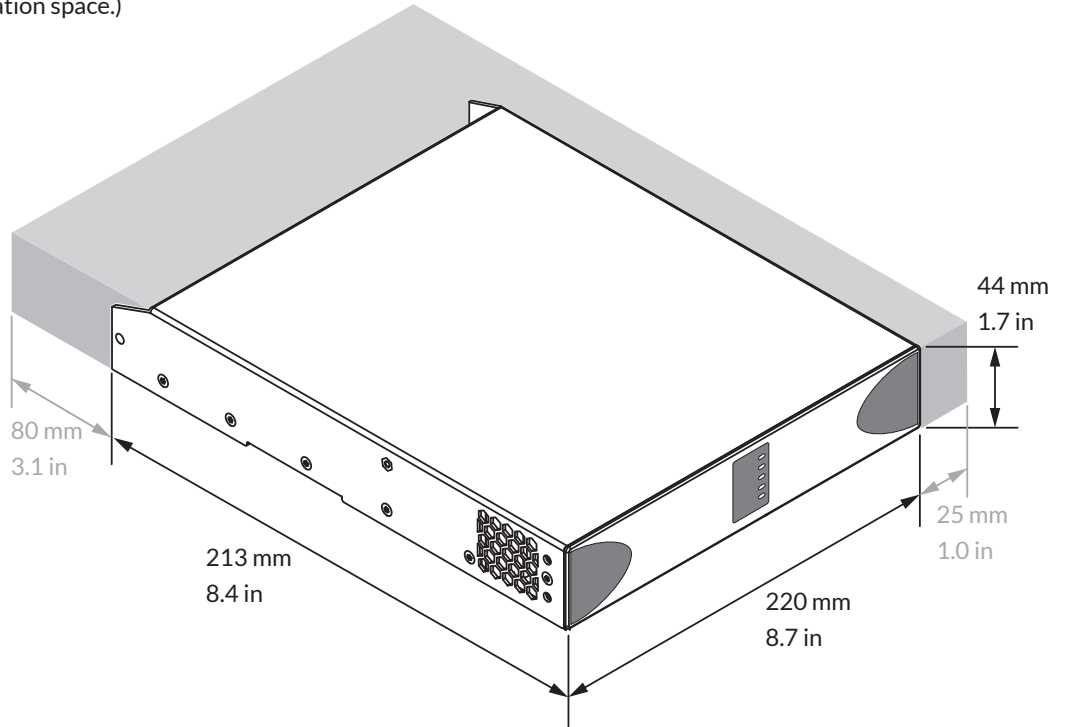
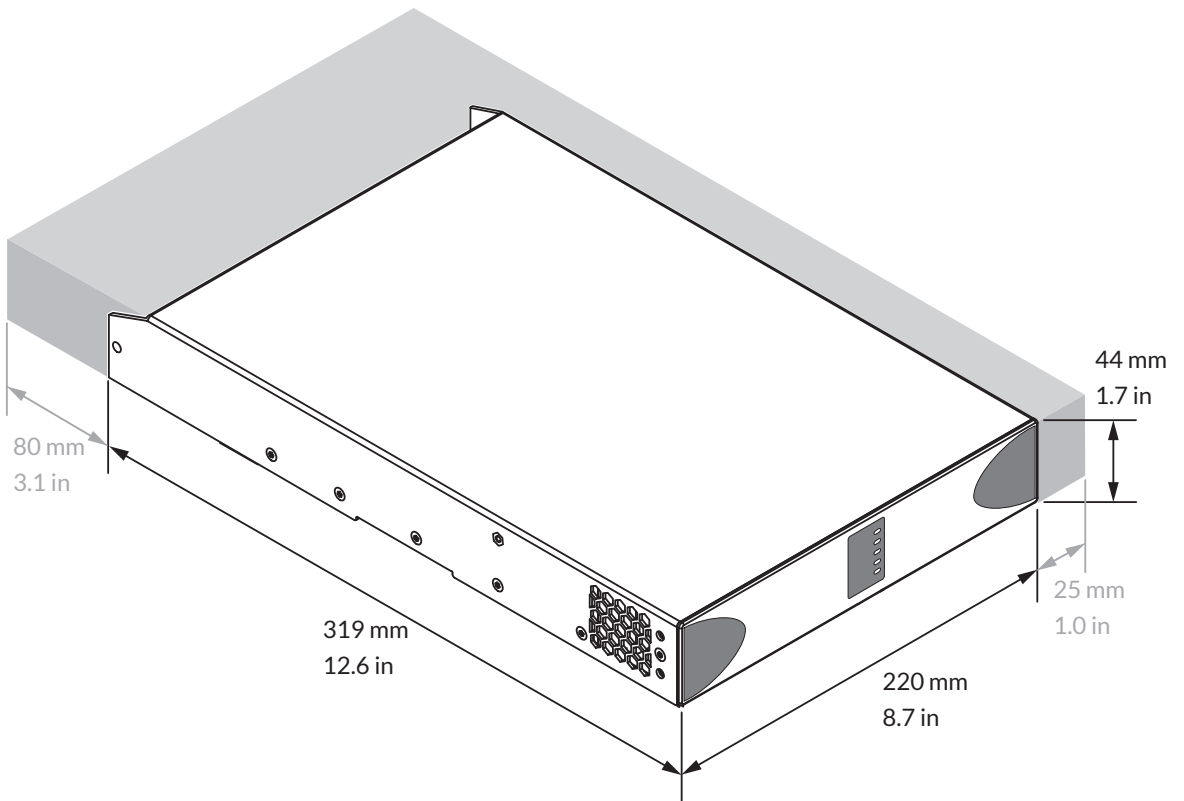

Diagram 1b

PowerZone Connect four channel amplifier dimensions.
(Shaded area defines ventilation space.)



Installation

4. Installation

Note: The rack mounting and desk/wall mounting components described and illustrated in Sections 4.1 to 4.3 are not supplied with PowerZone Connect amplifiers but are available to purchase as accessories. Contact your amplifier re-seller for more information.

4.1 PowerZone Connect Mounting

The **PowerZone Connect** amplifiers are shipped without rack mount hardware attached but can be configured for rack installation using one standard rack 'ear' and one half-rack extension piece as illustrated in **Diagram 3a**. The installation and equipment rack should be configured to provide appropriate ventilation airflow space around the sides and rear of the amplifier as illustrated in as illustrated in **Diagram 1a**. Ventilation airflow space of at least 25 mm (1 in) should be maintained along at least one side of the amplifier at all times. Ventilation apertures are also located on the rear panel of the amplifier and must not be obstructed. It is important to retain at least 80 mm (3.1 in) free space for airflow behind the amplifier rear panel.

In addition to rack mount ears, optional rack mount rear support hardware is available and can be attached to the amplifier. Rear support hardware may be appropriate if the amplifier is to be used in a mobile rack or potentially be subject to significant movement. **Diagram 3b** illustrates the use of rack mount rear support hardware.

Multiple **PowerZone Connect** amplifiers can also be mechanically connected using accessory connecting plates. **Diagram 3c** illustrates the use of connecting plates.

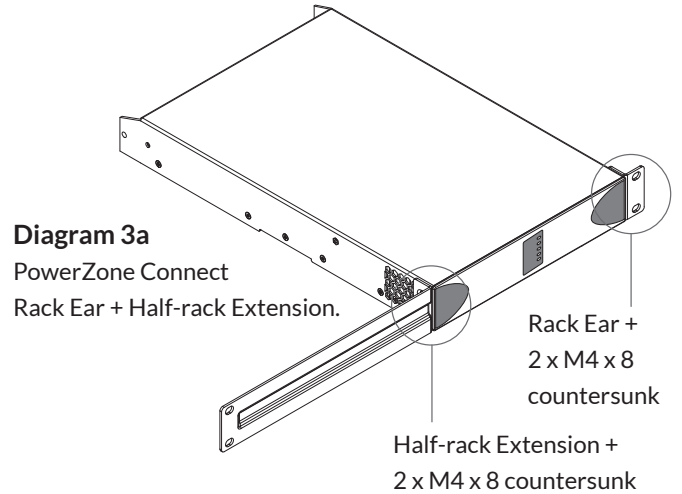
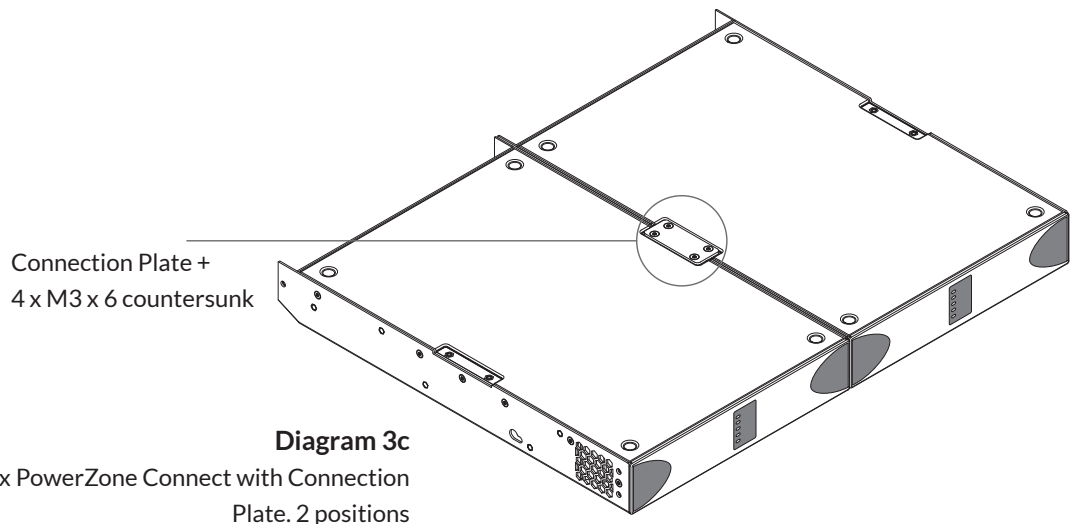
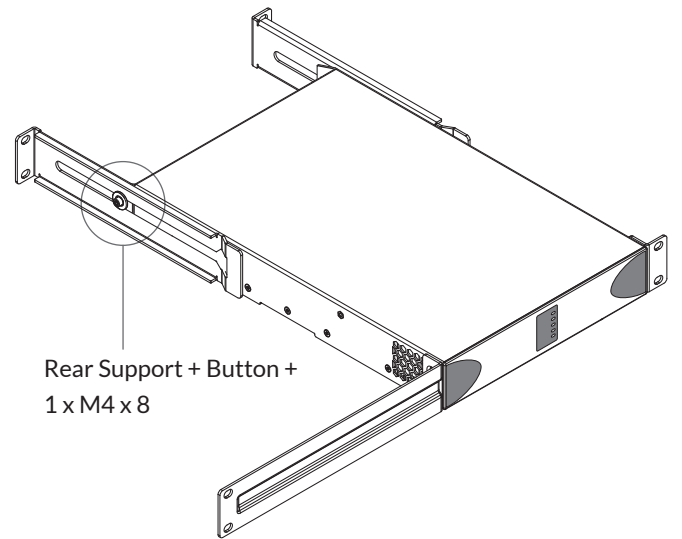

Diagram 3b
PowerZone Connect
Rack Support hardware. 2 positions.



Installation

4.2 Free-standing

If not installed in an equipment rack, PowerZone Connect amplifiers can be placed free-standing on a flat surface. Adhesive rubber feet are supplied for this purpose.

PowerZone Connect amplifiers can also be attached to the underside of desks or wall mounted using connecting plate hardware. The adhesive rubber feet should also be used in these circumstances to minimise the possibility of vibration between the amplifier and mounting surface. Wall and desk mounting is illustrated in **Diagrams 4a and 4b**.

It is important in any free standing installation that airflow through the amplifier's side panel mounted fans and rear panel ventilation apertures is not compromised by adjacent items. At least 80mm of free space behind the amplifier and 25mm along at least one side should be retained at all times.

Diagram 4a

PowerZone Connect with desk/wall Mounting Plate and adhesive feet. 2 positions and 4 positions.

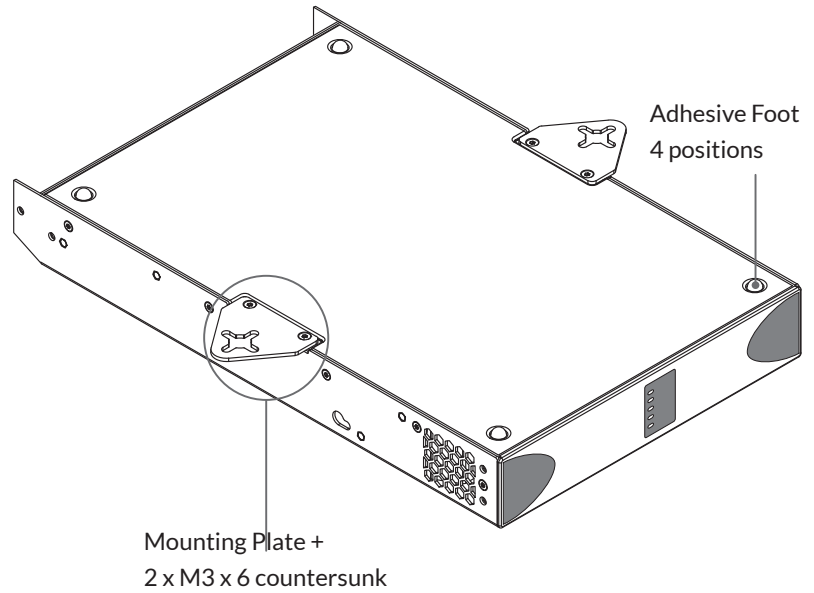
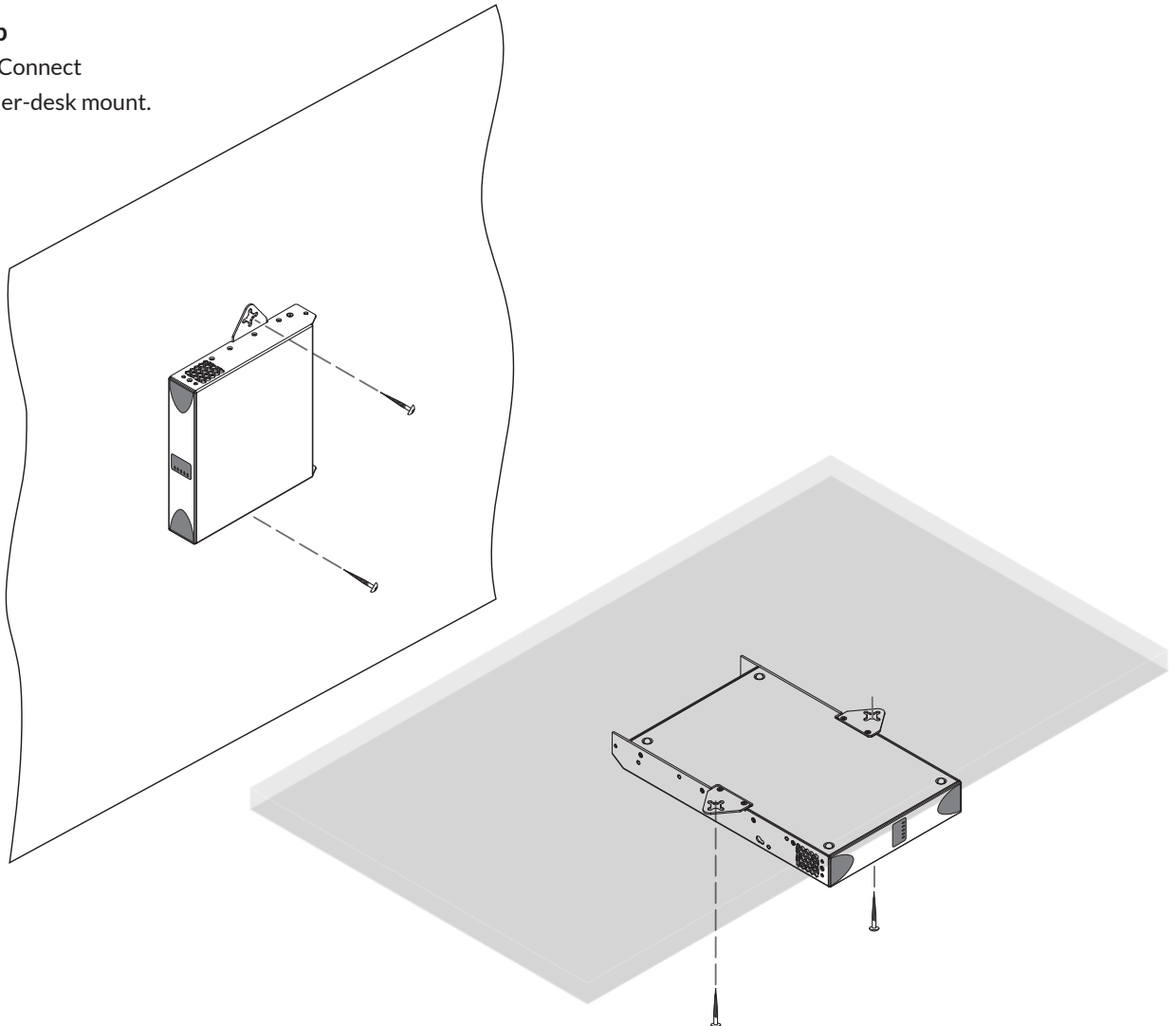

Diagram 4b

PowerZone Connect wall and under-desk mount.



Configuration

5. Configuration

Before making input, output and GPIO connections, an initial PowerZone Connect DSP amplifier configuration should be established. It is particularly important that the output amplifier format is configured appropriately for the speakers that are to be connected.

Configuration requires that PowerZone Connect DSP amplifiers are connected to mains power and network services. These connections are described in the following two sections.

5.1 Mains Power Connection

PowerZone Connect amplifiers incorporate a power factor corrected power supply and can be used with mains input voltage from 100V AC to 240V AC, 50/60Hz. Use the mains cable supplied with the amplifier and connect it to a switched mains supply.

PowerZone Connect amplifiers have no mains power switch and are operational as soon as mains power is connected.

5.2 Network Services

PowerZone Connect amplifiers are configured via a web page interface called PowerZone Control. Before the configuration menus can be accessed, PowerZone Connect amplifiers must be connected to the same TCP/IP network as the computer or mobile device that is to be used for configuration access.

Wired (Ethernet) Network Connection

To connect a PowerZone Connect amplifier to a TCP/IP network using a wired connection (Ethernet) follow the steps below.

1. Use an Ethernet cable to connect the PowerZone Connect amplifier rear panel Network Control socket to a free socket on a network router or network switch.
2. With the PowerZone Connect amplifier connected to mains power, wait for the front panel Network indicator to illuminate green to indicate that the amplifier has been assigned an IP address.
3. Use a network scanner app to identify the IP address assigned by the network router to the PowerZone Connect amplifier.
4. Open a computer or mobile device web browser and enter the IP address identified in the Step 3 above. The amplifier configuration web page interface will now open.

Note: If a PowerZone Connect amplifier is power cycled it is possible that the TCP/IP network router will assign it a different IP address, leaving its configuration page inaccessible via the previous address. If this occurs, a network scanning app can be used to identify the new IP address. Alternatively, the amplifier can be configured to use a fixed IP address via the LAN configuration menu.

Wireless (WiFi) Network Connection

To connect a PowerZone Connect amplifier to a TCP/IP network using a wireless connection (WiFi) follow the steps below.

1. With the PowerZone Connect amplifier connected to mains power, wait for the front panel WiFi indicator to illuminate green.
2. Use a mobile, laptop or desktop device to search for available WiFi networks. Connect to, PowerZone Connect (product serial number) using the password, 'password'. The amplifier serial number can be found on its rear panel.
3. Open a computer or mobile device web browser and enter the IP address: 192.168.4.1. The amplifier configuration web page interface will open.
4. Select the Settings tab followed by WiFi > WiFi Mode > Client to configure the amplifier to connect to the required WiFi network. The WiFi network name and password will be required.

It is strongly recommended that the PowerZone Connect amplifier Access Point WiFi password is changed following initial wireless connection.

Configuration

5.3 Configuration Menus

Opening a web browser that is network connected to a PowerZone Connect amplifier initially displays PowerZone Control Web App Dashboard screen illustrated in **Diagram 5a**. The Dashboard is the 'home' screen from which all other configuration options can be accessed.

The Dashboard screen shows the amplifier status and output zones on the right and the configuration menu access tabs on the left. The functions available under each tab are as follows.

Input Tab

The **Input Tab** provides **naming, mono/stereo selection, sensitivity, and gain trim** for each amplifier input channel. An internal pink noise source, provided for system testing and set up, can also be enabled or disabled and adjusted for gain via the Input Tab.

Zone Tab

The **Zone Tab** enables installation zones to be defined and named, and provides access to further sub-menus. Zones might be bar or restaurant areas for example, or different rooms in a home. For all Zone Tab menus, the installation zone under configuration is selected by highlighting one of the zone identifiers (A, B, C or D) at the top of the page.

- The **Source** menu option enables inputs to be assigned to installation zones.
- The **GPIO Volume Control** option enables external volume control to be applied to individual installation zones. The GPIO configuration menu can be found under the **Settings Tab**.

- The **Compressor** option enables default or custom signal compression to be applied to individual installation zones.

Note: Compression can be useful to reduce the volume difference between loud and quiet audio material. The lower the compression threshold is set, the more the difference between loud and soft will be reduced. The overall zone volume may need to be increased when compression is used. The default compression parameters are appropriate for most installations.

Output Tab

The **Output Tab** enables amplifier outputs to be named and provides access to further sub-menus. For all Output Tab menus, the amplifier output under configuration is selected by highlighting one of the output identifiers (1, 2, 3 or 4) at the top of the page.

Note: The number of individual outputs available for configuration will depend on the PowerZone Connect amplifier model and the input, zone and output mode configuration.

- The **Routing** menu enables zones to be assigned to amplifier outputs.
- The **Delay** menu enables delay to be applied to individual amplifier outputs.
- The **Equalizer** menu enables parametric equalization to be applied to individual amplifier outputs. Equalizer settings configured for one amplifier output can be copied and applied to other outputs.
- The **Crossover & Gain** menu enables high or low-pass crossover filters and gain adjustment to be applied to individual amplifier outputs. Crossover filter settings configured for one amplifier output can be copied and applied to other outputs.

- The **Speaker EQ** menu enables parametric equalization to be applied to individual amplifier outputs following the application of crossover filtering. Equalizer settings configured for one amplifier output can be copied and applied to other outputs.
- The **Driver Alignment** menu enables delay to be applied to individual amplifier outputs following the application of crossover filtering.

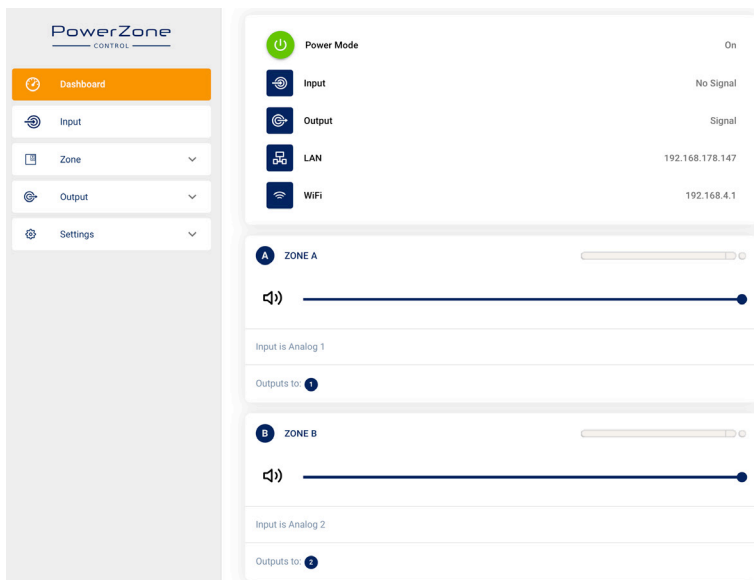

Diagram 5a
Configuration Dashboard Display
(two channel amplifier model)

Configuration

- The **Polarity** menu enables the polarity of individual amplifier outputs to be reversed.
- The **Limiter** menu enables signal limiting to be applied to individual amplifier outputs.

Note: An output limiter can be used to restrict the peak volume level from speakers connected to each output.

- The **Output Mode** menu enables individual amplifier outputs to be switched off or configured for Lo-Z or Hi-Z modes. In Hi-Z modes, a high-pass filter can also be configured and applied to the output.

Note: Use of a high-pass filter with Hi-Z mode loudspeakers is useful to avoid the possibility of distortion caused by low frequency line transformer saturation. Begin with the default filter setting of 70Hz. If low frequency distortion is still audible, increase the frequency setting one step at a time until the distortion is no longer audible.

Settings Tab

The **Settings Tab** enables miscellaneous amplifier settings to be configured and installation data to be recorded. The Settings Tab provides access to further sub-menus.

- The **System Information** menu provides text fields for the recording of installation data.
- The **Device** menu records amplifier specific information such as the model number and firmware version. A firmware update routine and identifier button can also be found under the Device menu.

- The **Backup & Restore** menu enables amplifier configuration data to be downloaded to an external archive, and enables previously saved configuration files to be uploaded and adopted by the currently connected amplifier.
- The **Power Management** menu enables various automatic switch-on options to be engaged. The Power Management menu also offers timed Standby and Mute functions.
- The **GPIO** menu enables configuration of the multi-purpose GPIO interface pins.
- The **LAN** menu enables configuration and reset of the wired network options and parameters.
- The **WiFi** menu enables configuration and reset of the wireless network options and parameters.

5.4 Setup and Signal Routing

Thanks to their network based configuration features, PowerZone Connect amplifiers offer considerable versatility in terms of sources, signal routing, installation zones and output modes. Inputs can be freely assigned to installation zones, and those zones assigned freely to the available amplifier outputs in either Lo-Z or Hi-Z modes.

This versatility enables, for example, one amplifier simultaneously to drive both Lo-Z and Hi-Z speakers, or for different inputs to be routed to different output zones.

The following paragraphs describe and illustrate the recommended procedure for configuring input, zone and output routing. A general signal flow schematic is also illustrated in **Diagram 5f**.

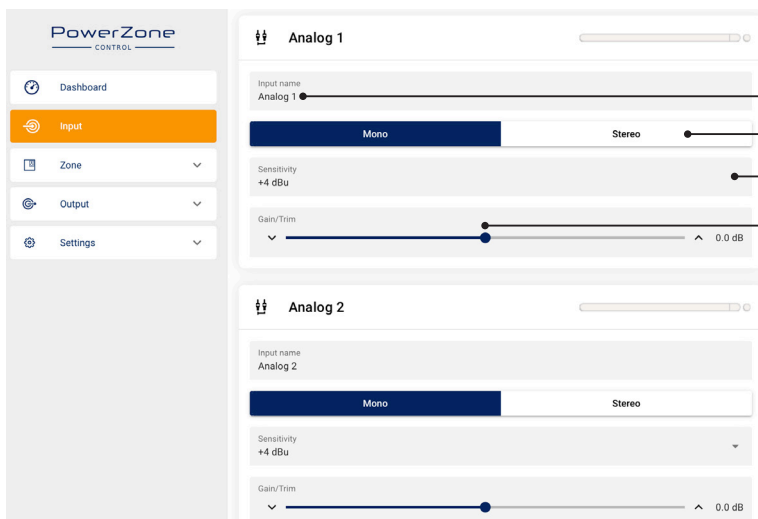

- Input name. Type to edit.
- Define a mono or stereo input.
- Select an input sensitivity option.
- Adjust input gain using the slider or the up/down icons. The input level display should remain in the green band. If it displays red, the input gain should be reduced.

Diagram 5b
Input Tab Display
(two inputs only shown)

Configuration

Input Setup

Open the configuration Dashboard and select the **Input Tab**. The Input Tab is shown in **Diagram 5b**.

- To edit default input names simply select and type in the Input Name field.
- Define a mono or stereo input by selecting the appropriate option. Defining a stereo input will reduce the total number of discrete inputs available.
- Select an input sensitivity option from the drop-down menu: +14dB, +4dB, -10dB and 'microphone' options are available. Generally, the +14dB or +4dB options are appropriate for 'professional audio' source hardware with balanced outputs, while the -10dB option is more appropriate for 'consumer audio' source hardware with unbalanced outputs. The 'microphone' option provides the significantly greater sensitivity required for microphones.

Note: Only dynamic microphones are suitable for connection. Phantom power for condenser microphones is not provided.

- If necessary, adjust the input gain using the slider or up/down icons. Gain adjustment is intended to be used for fine output level adjustment following initial use.

Zone Setup & Routing

Open the configuration Dashboard and select the **Zone Tab**. The Zone Tab is shown in **Diagram 5c**.

- Select the zone to be configured. The number of zones available will depend on the amplifier model, input setup and output mode (Lo-Z or Hi-Z). For example, a two output amplifier will have two zones available if only mono inputs configured, but have only one zone available if any stereo input is configured. Similarly, a four output amplifier with only mono inputs configured but one output configured for Hi-Z mode will have only three zones available.

Note: When configured in Hi-Z mode PowerZone Connect amplifiers operate in 'bridged' mode where the output of two channels is combined. This means that the number of output channels available in Hi-Z mode is half that available in Lo-Z mode

- Name the zone by typing in the Zone Name field.
- Adjust the zone volume if required by using the slider.
- Define a mono or stereo zone by selecting the appropriate option. Defining a stereo zone will reduce the total number of further zones available.
- Specify an input for the zone by selecting from the drop-down menu. Selecting a stereo input for a mono zone will automatically sum the stereo channels to mono.

Diagram 5c

Zone Tab Display

(two inputs only shown)

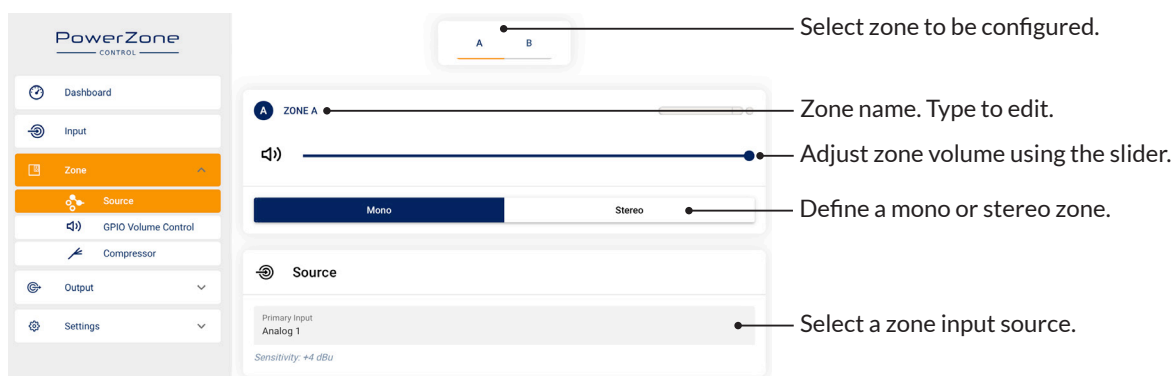

Configuration

Output Setup

Open the configuration Dashboard and select the **Output Tab**. The Zone Tab with its **Routing** menu selected is shown in **Diagram 5d**.

- Select the output to be configured. The number of outputs available will depend on the amplifier model, zone setup and output mode. For example, a two output amplifier will have two outputs available if Lo-Z mode is selected but only one output available if Hi-Z mode is selected.
- Specifying a Zone as stereo will automatically generate three output channel options: left channel, right channel or summed mono. The summed mono signal can potentially be used to drive a subwoofer.

The Zone Tab with its **Output Mode** menu selected is shown in **Diagram 5e**.

- Select the mode required for the output. The number of outputs available will depend on the amplifier model, input setup and zone setup. For example, a two output amplifier will have two outputs available if Lo-Z mode is selected but only one output available if Hi-Z mode is selected.

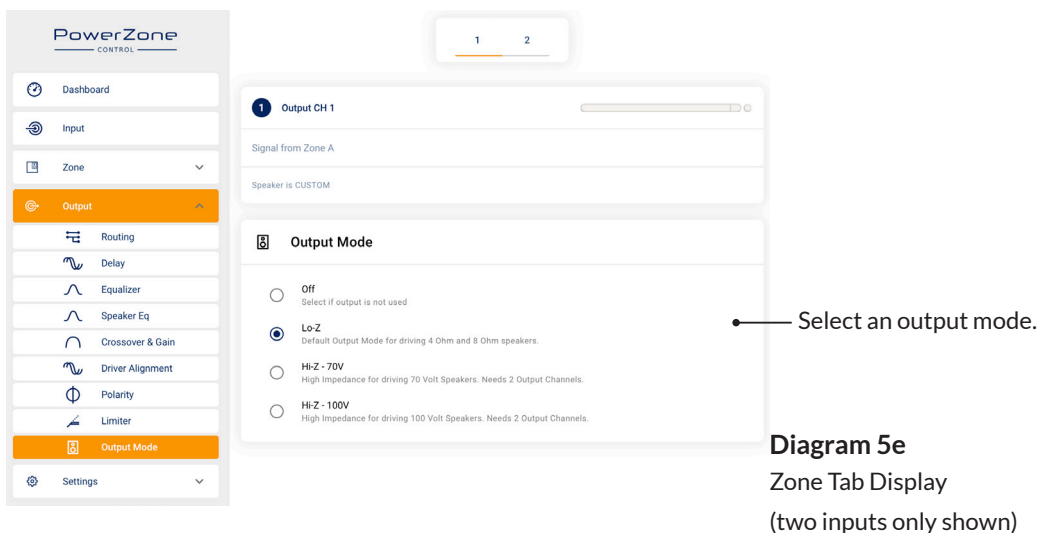
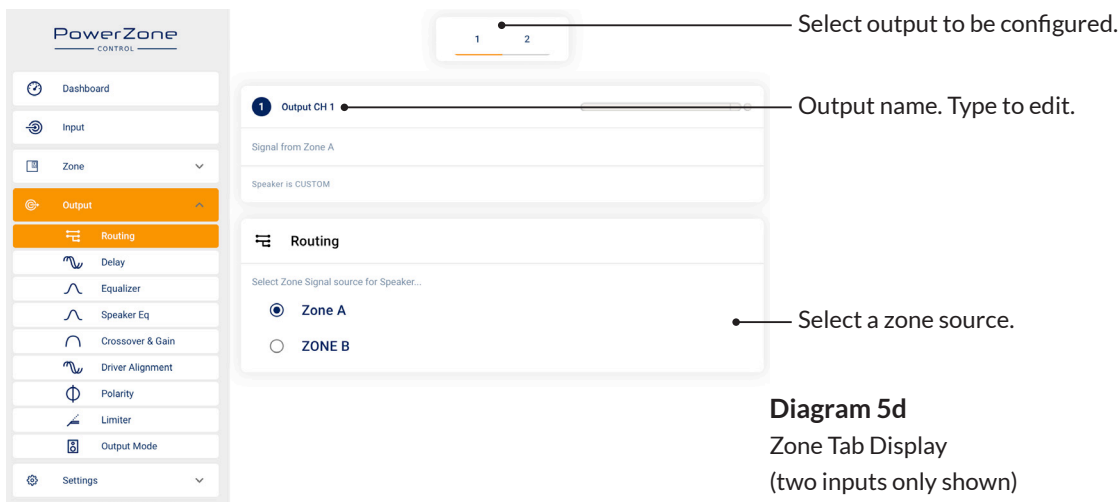

Configuration

Diagram 5f
Signal Flow Schematic
(four output amplifier)

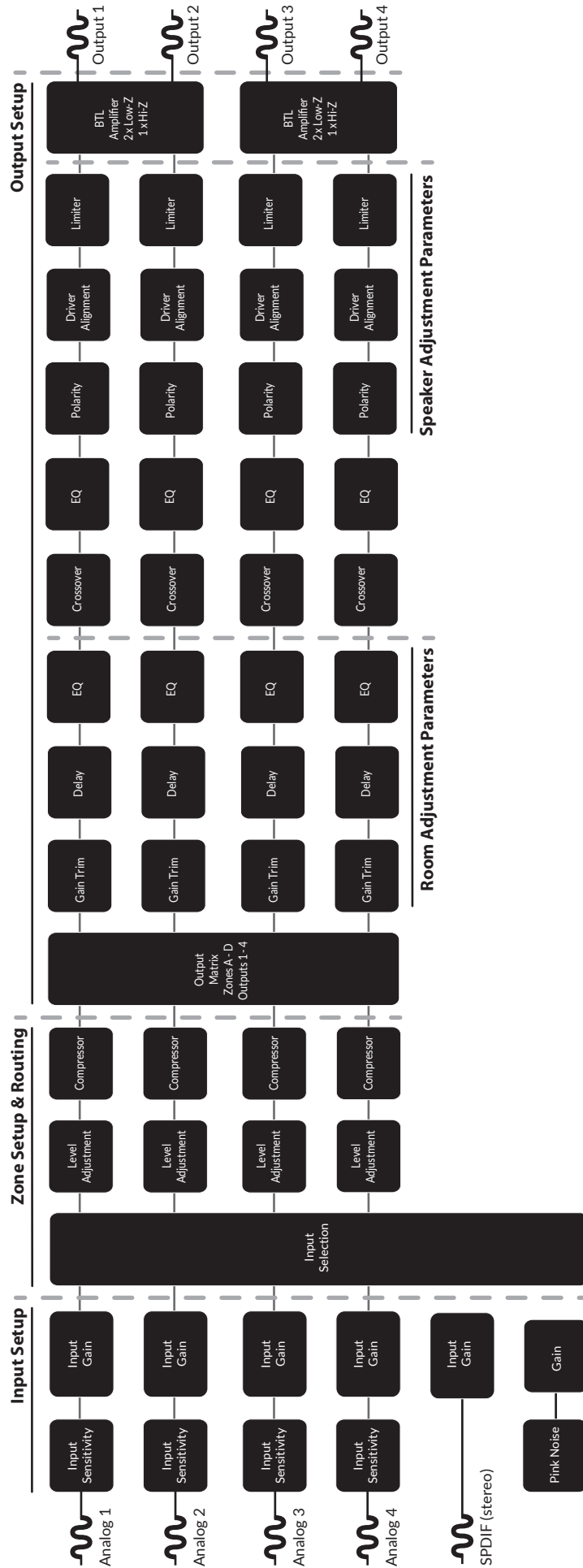

Configuration

5.4 GPIO Setup and Connection

PowerZone Connect amplifiers provide a GPIO socket that enables remote control of volume, standby, mute and trigger functions. The GPIO connector pin functions are described in the **GPIO Settings** menu illustrated in **Diagram 5g**. The connection of GPIO based remote volume control and standby/mute are illustrated in **Diagram 5h** and **Diagram 5i** respectively.

Diagram 5g
GPIO Settings Menu

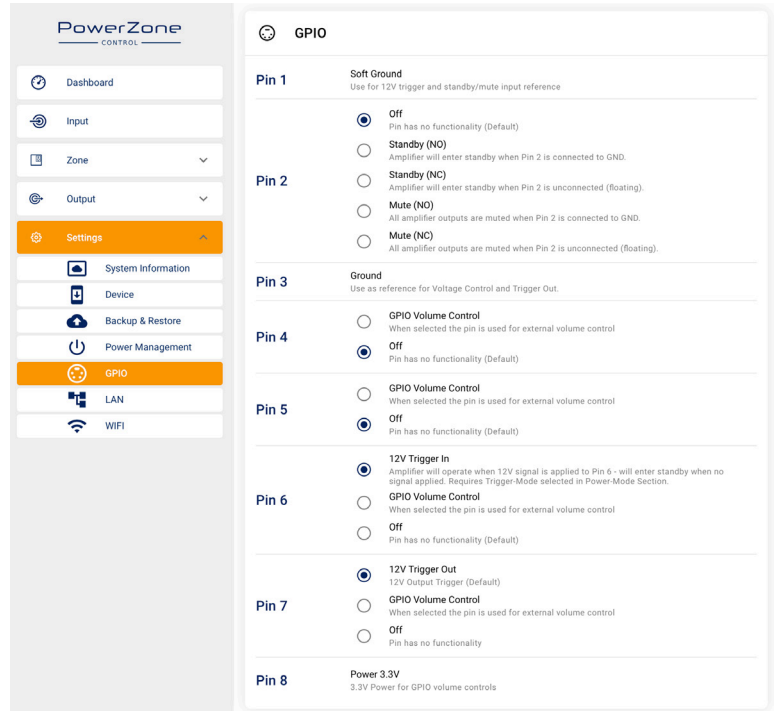

Note: The GPIO connector must not be used for any unintended purpose. Amplifier damage may result from incorrect use of GPIO.



Note: Shielded cable must be used when connecting standby switches and potentiometers and via GPIO.



Note: GPIO Pin 8 has an output impedance of 1kΩ. Connected devices must be able to sink 3.3mA.

Diagram 5h

Potentiometer connections for remote volume control via GPIO.

Note: Diagram 6c illustrates use of the GPIO connector.

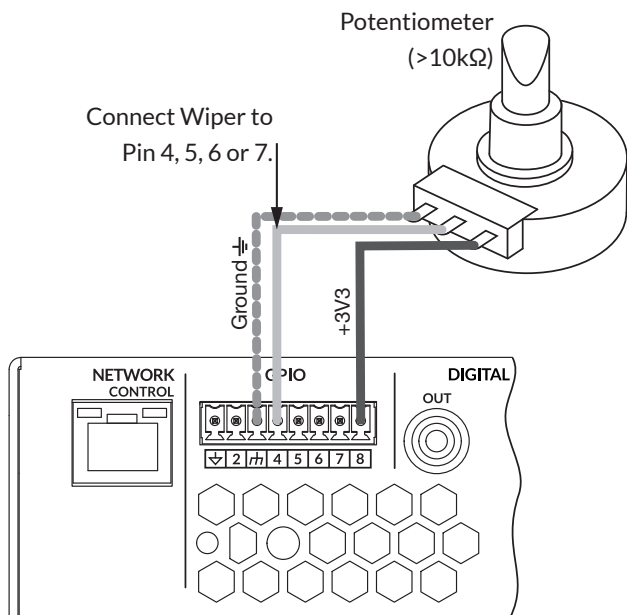
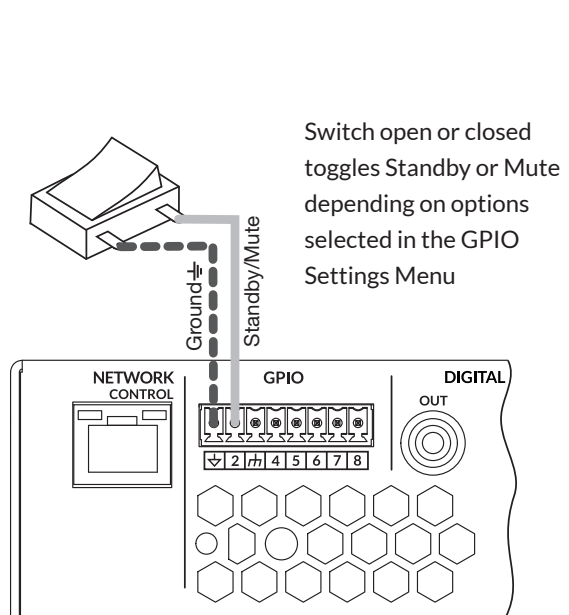

Diagram 5i

Connections for remote standby/mute switch via GPIO.

Note: Diagram 6c illustrates use of the GPIO connector.



Connections

6. Connections

PowerZone Connect amplifier rear panel connections are illustrated in Diagrams 6a.

6.1 Mains Power Connection

PowerZone Connect DSP amplifiers incorporate a power factor corrected universal power supply and can be used with mains input voltage from 100V AC to 240V AC, 50/60Hz. Use the mains cable supplied with the amplifier.

PowerZone Connect DSP amplifiers have no mains power switch and are operational as soon as mains power is connected. **Ensure that all signal, GPIO and output connections are made before connecting the amplifier to mains power.**

6.2 Input Connection

All PowerZone Connect amplifier models provide four balanced or unbalanced analog audio inputs and a stereo S/PDIF digital audio input. Any input channel can be routed to any output channel. Input routing options can be configured via the amplifier network interface. See **Section 5** of this manual.

Analog Inputs

PowerZone Connect analog inputs are of line level format with a default input sensitivity of +4dBu (full output voltage swing/sensitivity) in all output modes. Input signal levels up to +24dBu can be handled without input clipping. Input sensitivity options can be set via the amplifier network interface. See **Section 5** of this manual.

Balanced input connections to the amplifiers are made via male 'Euro Block' connectors. Connecting cables to the supplied female input connectors is illustrated in **Diagram 6b**.

Unbalanced input connections to the amplifiers are made via RCA phono sockets.

Digital Inputs

PowerZone Connect S/PDIF stereo digital audio input connections are made via a single RCA Phono socket

Note: An S/PDIF digital audio output socket is also fitted. The S/PDIF output signal by default reflects the input to amplifier installation zones A & B and is intended to be used for daisy-chaining PowerZone Connect amplifiers.

Note: 75Ω RCA Phono cables specifically intended for digital audio should always be used for S/PDIF connections. Standard Phono cables can be used but may not result in optimal performance.

6.3 Output Connections

Output connections from the amplifiers are achieved via male 'Euro Block' connectors. Ensure that speaker connection polarity is correct throughout the installation:

In the case of Lo-Z speaker connections, positive (+) amplifier terminals should always be connected to positive speaker terminals and negative (-) amplifier terminals always connected to negative speaker terminals.

In the case of Hi-Z speaker connections, the two speaker cable conductors should be connected between the positive (+) terminal of Output 1 and the negative terminal (-) of Output 2, and likewise for Outputs 3 and 4.

Output mode options (Lo-Z or Hi-Z) can be configured via the amplifier network interface. See **Section 5** of this manual.

Connecting cables to the supplied female **output** connector is illustrated in **Diagram 6c**.

Diagram 6a

PowerZone Connect rear panel connections.

Note: 2 output amplifier model connection sockets differ only in the deletion of channel 3 and channel 4 output connectors.

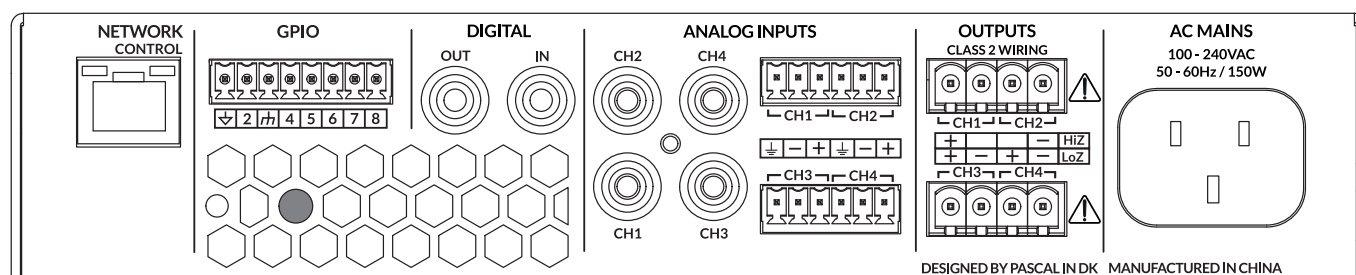

Connections

6.5 Speaker Cable Gauge

PowerZone Connect speaker connection cable gauge should be chosen appropriately to reflect the type of installation. The adjacent tables specify the appropriate cable gauge for less than 0.5dB cable loss with different installation types and cable lengths.

Cable Gauge Table

Lo-Z installations. 4Ω & 8Ω loads

Cable Cross Section (mm ²)	Cable Gauge (US)	Max Cable Length (metres, 4Ω load)	Max Cable Length (metres, 8Ω load)
0.5	≈20	2	5
0.75	≈18	4	8
1.5	≈16	6	12
2.0	≈14	9	19
4.0	≈12	14	30

6.5 GPIO Connections

If any PowerZone Connect GPIO functionality is required, cables will need to be connected to the supplied GPIO connector. Connecting cables to the GPIO connector is illustrated in **Diagrams 6d**.

Note: The GPIO GPO connection has an output impedance of 1kΩ. Connected devices must be able to sink 3.3mA. Shielded cables should be used.

Configuring GPIO functionality is described in **Section 5** of this manual.

Cable Gauge Table

70V Hi-Z installations. 60W & 125W power

Cable Cross Section (mm ²)	Cable Gauge (US)	Max Cable Length (metres, (125W/channel))	Max Cable Length (metres, (250W/channel))
0.5	≈20	84	42
0.75	≈18	132	66
1.5	≈16	210	105
2.0	≈14	334	166
4.0	≈12	532	265

6.6 Network Connections

PowerZone Connect amplifiers are TCP/IP network connected devices that are configured via a web page based interface. Wired (Ethernet) and wireless (WiFi) connection options are available. Connecting PowerZone Connect amplifiers to a TCP/IP network is described in **Section 5** of this manual

Cable Gauge Table

100V Hi-Z installations. 60W & 125W power

Cable Cross Section (mm ²)	Cable Gauge (US)	Max Cable Length (metres, (125W/channel))	Max Cable Length (metres, (250W/channel))
0.5	≈20	171	85
0.75	≈18	269	134
1.5	≈16	430	215
2.0	≈14	683	341
4.0	≈12	1087	542

Connections

Diagram 6b
Balanced analog input
cable connections.

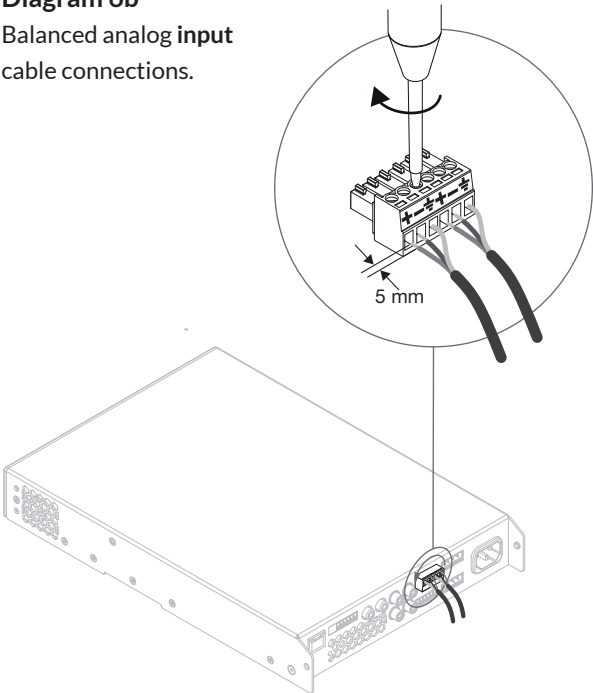

Diagram 6d
GPIO cable connections.

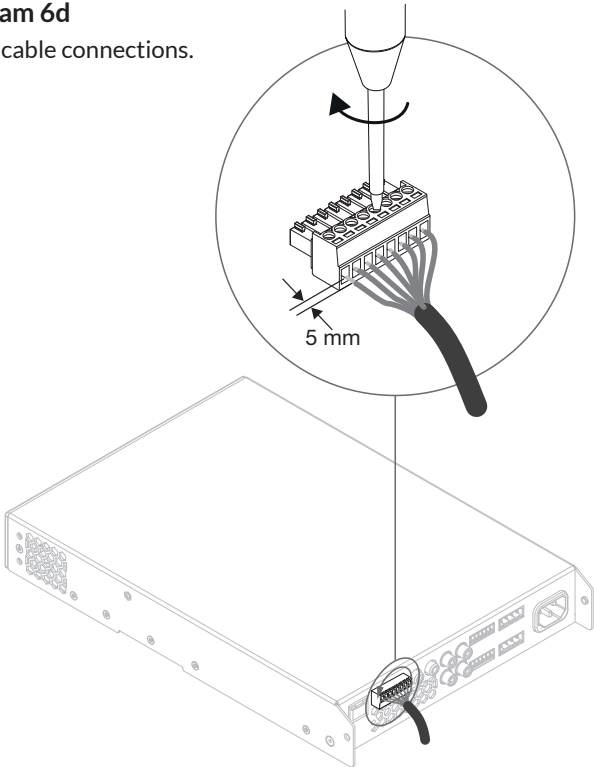
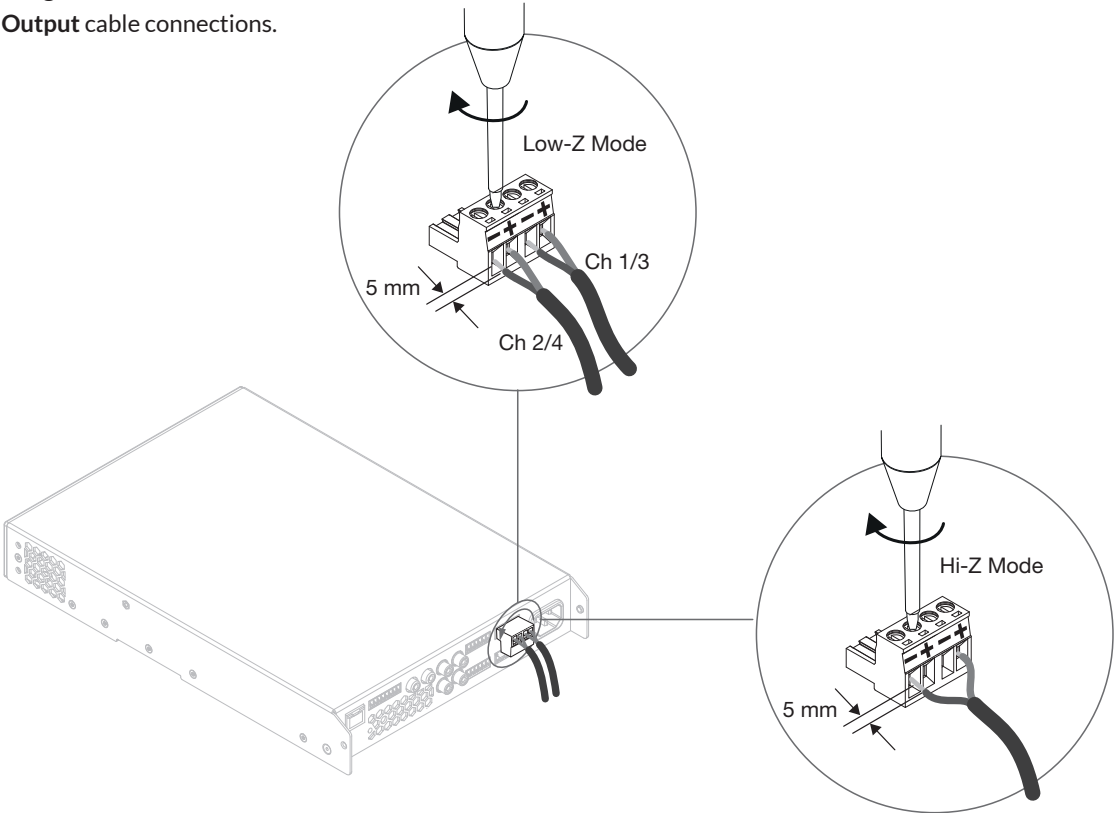

Diagram 6c
Output cable connections.



The exclamation point printed next to the output terminals of the amplifiers is, in addition to the CLASS 2 WIRING text, intended to alert users to the risk of hazardous voltages. Output connectors that could pose a risk are marked with the exclamation point. Do not touch the output terminals while the amplifier is switched on. Make all connections with the amplifier switched off.

Operation

7. Operation

Once all connections have been made and configuration options selected, PowerZone Connect amplifiers are ready for use. If an input signal above -60dB is present on any input, the front panel Input and Standby indicators will illuminate green to indicate normal amplifier operation. Audio will be heard from any connected speakers.

Note: PowerZone Connect amplifiers will not switch on from Standby Mode unless an input signal is present or a network or external standby switch is operated.

Amplifier outputs will mute if no input signal is present for 5 minutes, and the amplifier will switch automatically to Standby Mode if no signal is present on any input for more than 15 minutes. Alternative standby and mute delay times can be selected via the **Settings Menu**. Amplifier cooling fan speed is temperature controlled. The fan will switch off when the amplifier enters standby mode.

7.1 Front Panel Indicators

PowerZone Connect amplifier front panel indicators illuminate to indicate the following operational states:

- Status:** Off – Mains power disconnected.
Green – Amplifier operational.
Pulse Green – Standby Mode.
Amber – GPIO triggered Standby Mode
- Input:** Off – No input signal present.
Green – Signal present on one or more inputs.
Amber – Signal limiting/clipping on one or more inputs.
- Output:** Off – No output signal present.
Green – Signal present on one or more outputs.
Amber – Signal limiting/clipping on one or more outputs.
Red – One or more channel pair is in overload/protection mode.
- Network:** Off – No Ethernet network detected.
Green – Ethernet network detected.
- WiFi:** Off – WiFi disabled.
Green – WiFi enabled.

7.2 Automatic Power Sharing

PowerZone Connect DSP amplifiers incorporate a power sharing feature that automatically shares the total power available from the amplifier's internal power supply across each pair of output channels. If one channel temporarily demands more than the amplifier's continuous power rating while other channel is demanding less, the excess power available from the internal power supply is automatically made available to the over-power channel. Power sharing optimises the amplifier's ability to deliver maximum power into dynamic loudspeaker loads when playing music programme material.

Specifications

Model	PowerZone Connect 122	PowerZone Connect 252	PowerZone Connect 254	PowerZone Connect 504
Total System Power	125 W	250 W	250 W	500 W
Output Power @ 4/8Ω	2 x 60 W	2 x 125 W	4 x 60 W	4 x 125 W
Output Power @ 70/100V*	1 x 125 W	1 x 250 W	2 x 125 W	2 x 250 W
Powershare (up to) Across all channels**	1 x 125 W	1 x 250 W	1 x 250 W	2 x 250 W
Power Consumption	75W	75W	75W	150W
Dimensions	44 x 220 x 213 mm (1.7 x 8.7 x 8.4 in)	44 x 220 x 213 mm (1.7 x 8.7 x 8.4 in)	44 x 220 x 319 mm (1.7 x 8.7 x 12.6 in)	44 x 220 x 319 mm (1.7 x 8.7 x 12.6 in)
Weight	2kg (4.4 lbs)	2kg (4.4 lbs)	2.8kg (6.2 lbs)	2.8kg (6.2 lbs)
Output Circuitry	UMAC™ Class D - full bandwidth PWM modulator with ultra-low distortion			
Output Voltage	70Vp / 140Vpp (unloaded) // Bridged 140Vp / 280 Vpp (unloaded)			
Signal To Noise-Ratio	>106dB (A-weighted, 20Hz-20kHz, 8Ω load)			
THD+N (typical)	< 0.05% (20Hz-20kHz, 8Ω load, 3dB below rated power)			
Frequency Response	20Hz-20kHz (+0/-0.25dB (8Ω load, 3dB below rated power)			
Protection Circuits	Short circuit -, DC -, Undervoltage -, Temperature - and Overload protection			
Power Supply	UREC™ universal mains switch mode power supply with Power Factor Correction (PFC) and standby converter			
Operating temperature	0-40°C			
Operating Voltage/ Frequency	Universal Mains, 100V-240V, 50Hz-60Hz			
Standby Consumption	< 0.5W			
Accessories	2x Rack ears 1x ½ rack plate extension 2x ½ rack mounting 2x Rear supports			
Power Ratings	1% THD @ 120Vac and 230Vac			

*100V line mode is @ -1dB (≈ 90 V)

**504 may only Powershare across Ch1/2 and Ch3/4

BLAZE

Blaze Audio, Pascal A/S, Ellekaer 6, DK-2730 Herlev, Denmark. hello@blaze-audio.com. www.blaze-audio.com

Rev G/01/2022