

SYSTEMS AND CONTROL / ZONE SYSTEMS / DIGITAL

MCMD-1

DANTE DESKTOP MICROPHONE



- ✓ Crystal clear voice pick-up
- ✓ Push to speak PTL
- ✓ DANTE digital audio transmitter



+ Info:
<https://fonestar.com/MCMD-1>

ESPECIALLY RECOMMENDED IN:



Sports facilities



Hotels



All sectors

DESCRIPTION

Desktop microphone with DANTE digital audio output. Allows digital audio to be transmitted over the data network with the DANTE protocol. For installations with DANTE digital audio transmission, shopping centres, hotels, conference rooms, etc.

TECHNICAL CHARACTERISTICS

FEATURES	<p>Desktop microphone. DANTE digital audio transmitter. Gooseneck microphone. Push to speak PTL. Call indicator lights. Robust metal construction. Great stability.</p>
MICROPHONE	Electret condenser with gooseneck
INPUTS	1 x balanced microphone, XLR 600 Ohm. Phantom 37 V power supply
OUTPUTS	1 x LAN port for local area network connection, RJ-45
CONTROLS	Push button with PTL function, press to talk (on), and press to close (off)
POWER SUPPLY	POE
DIMENSIONS	Gooseneck microphone: 440 mm high Base: 125 x 55 x 165 mm depth
ACCESSORIES	Wind-shield foam



+ Info:
<https://fonestar.com/MCMD-1>

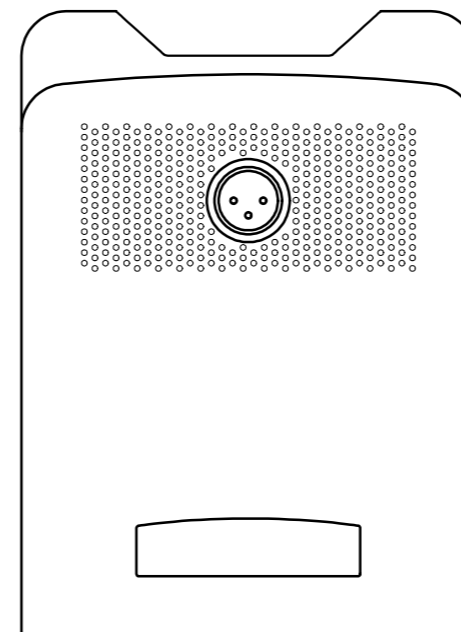
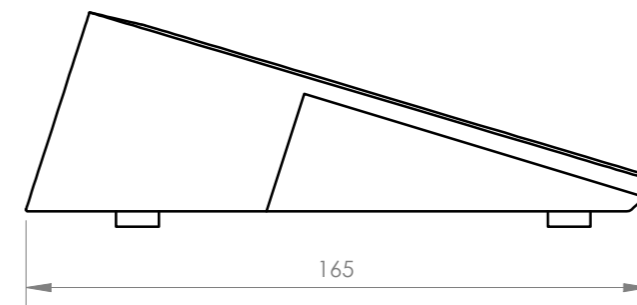
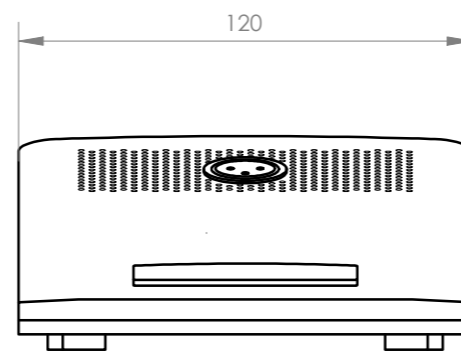
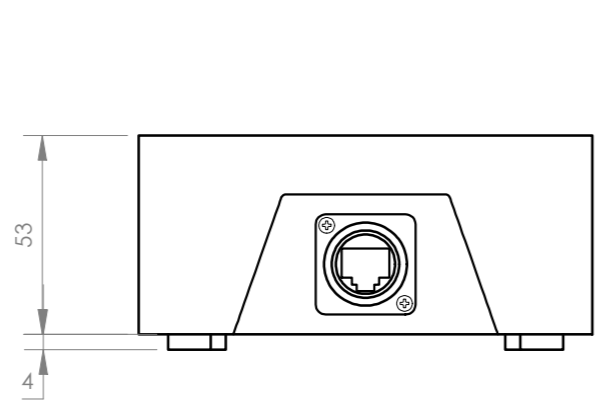
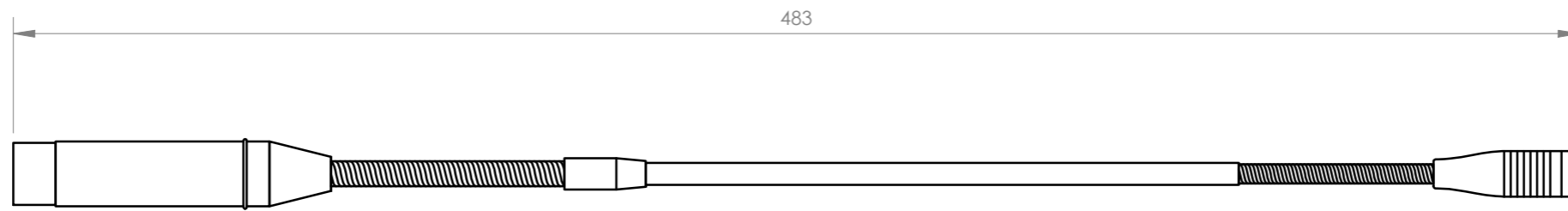

FONESTAR	Model	Description	Units	Scale
	MCMD-1	DANTE DIGITAL AUDIO DESKTOP MICROPHONE	mm	1:2