

AV MULTIMEDIA / EXTENSIONS / HDMI

FO-473-TX

HDMI EXTENSION-DISTRIBUTOR TRANSMITTER VIA CAT 6 CABLE

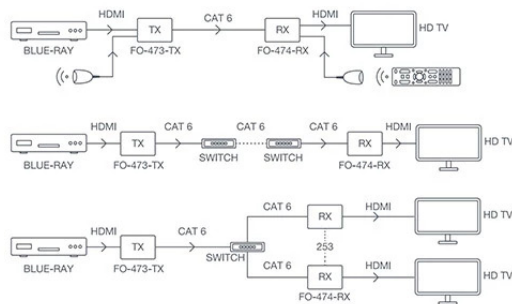

- ✓ Distributes and extends HDMI signal over IP (transmitter)
- ✓ FULL HD 1080p resolution@ 60Hz
- ✓ Signal transmission up to 120 m. Direct or Ethernet connection with 1 Gigabit switch
- ✓ 1.3 HDMI
- ✓ 1.4 HDCP, compatible with 1.3

ESPECIALLY RECOMMENDED IN:



Hospitality



Education



Offices



All sectors



+ Info:
<https://fonestar.com/FO-473-TX>

DESCRIPTION

HDMI 1.3 extension-distributor transmitter over IP. The main function of the FO-473-TX transmitter and FO-474-RX receiver set is to transmit HDMI and remote control signals over long distances without signal or quality loss. With this extension, a 1080p@60Hz signal can reach up to 120m using Cat 6 cable. In addition, it is possible to increase this maximum distance with the use of Gigabit switches (1 Gbps) and IGMP Snooping function, extending an additional 120 metres with each switch added to the installation. All this through a quick and easy PnP installation. It features HDMI signal compression and transmission technology by HDbitT with reduced bandwidth (18 Mbps). As a result, the system is easily scalable and can be connected directly or point-to-multipoint. The FO-473-TX transmitter can be connected directly to a single FO-474-RX receiver, via a direct cable or via Ethernet network; or to multiple receivers (up to 253 receivers), via Ethernet network. The advantages of using data cables instead of HDMI cables are numerous. It allows for easy installation of cabling through pipes, walls or ceilings, dramatically increases the distance between the HDMI equipment and the monitor or projector, reduces cabling costs and uses RJ-45 connectors that can be easily installed without the need for soldering. Ideal for installations where the video source is far away from the TV or projector and need some versatility to extend the installation, such as in exhibitions, shop windows, training rooms, conference rooms, sports centres, bars, restaurants, etc.



+ Info:

<https://fonestar.com/FO-473-TX>

TECHNICAL CHARACTERISTICS

FEATURES	<p>HDMI 1.3 extension-distributor transmitter over IP 1080p@60Hz resolution. Bandwidth 4.95 Gbps. Transmission distance up to 120 m with direct connection with Cat 6 cable for 1080p resolution. Extendable up to 120 m with each switch level. Direct or ethernet connection with Gigabit switch (1 Gbps) with IGMP Snooping function. Flexible and scalable configuration. Easy HDMI signal distribution. Point-to-multipoint transmission from one FO-473-TX to one or more FO-474-RX receivers. Up to 253 FO-474-RX receivers. Low bandwidth data transmission and compression technology, 18 Mbps. Remote control extension function for source control from the receiver location.</p>
HDMI	1.3
HDCP	1.4, compatible with 1.3
DELAY	100 ms
INPUTS	1 x HDMI female
OUTPUTS	1 x RJ-45 ethernet extension HDMI via Cat 5e/6 cable
RECEIVER	Mod. FO-474-RX
POWER SUPPLY	5 V DC, 2 A with adapter included
DIMENSIONS	100 x 25 x 59 mm depth
WEIGHT	0.15 kg
ACCESSORIES	Remote control extender cable Assembly mounts
NOTE	<p>It is recommended to use high quality Cat 6 cables with FTP/SFTP shielding. Cables should have shielded connectors with the cable shielding connected to the connector shield. This improves the reliability of HDMI extenders, preventing ground loops produced when interconnecting devices (player/receiver and TV) with different ground references which may cause loss or break-up of the picture.</p>



+ Info:
<https://fonestar.com/FO-473-TX>

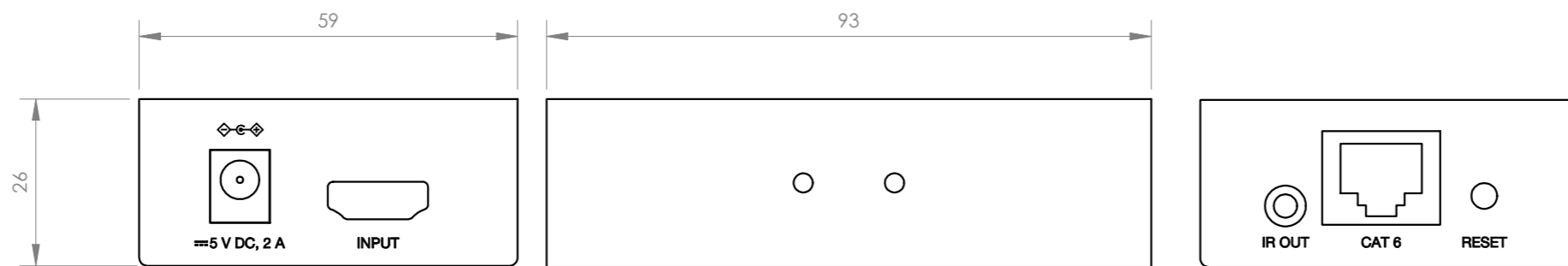

FONESTAR	Model	Description	Units	Scale
	FO-473-TX	HDMI EXTENSION-DISTRIBUTOR TRANSMITTER VIA CAT 6 CABLE	mm	1:1